

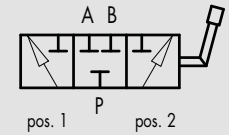

SCHEMA IDRAULICO
(con centro aperto)
HYDRAULIC DIAGRAM
(with opened centre)

A RICHIESTA
(con centro chiuso)
ON REQUEST
(with closed centre)

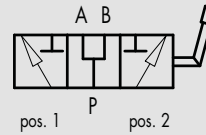

IMPIEGO:

Valvole utilizzate per deviare il flusso in ingresso verso due bocche d'uscita.

MATERIALI E CARATTERISTICHE:

Corpo: ghisa

Componenti interni: acciaio temprato termicamente e rettificato

Guarnizioni: BUNA N standard

Tenuta: trafileamento trascurabile

MONTAGGIO:

Collegare P all'alimentazione e le bocche A e B ai rami del circuito idraulico a cui si vuole deviare il flusso. Con leva in pos. 1 si alimenta la bocca A, con leva in pos. 2 si alimenta la bocca B. Con leva in posizione centrale le bocche P, A e B sono tutte collegate (centro aperto).

A RICHIESTA:

- Centro chiuso (CODICE/CC)
- Alta pressione - fino a 400 Bar (CODICE/AP)

USE AND OPERATION:

3 ways diverter valves is used to divert the flow towards 2 different outlets.

MATERIALS AND FEATURES:

Body: cast iron

Internal parts: hardened and ground steel

Seals: BUNA N standard

Tightness: minor leakage

APPLICATIONS:

Connect P to the pressure flow, A and B to the ports of the hydraulic circuit where flow has to be diverted. With lever in position 1 the flow is connected towards port A; with lever in position 2, the flow is connected towards port B. With lever in central position ports P, A and B are all connected (open centre).

ON REQUEST

- Closed centre (CODE/CC)
- High pressure - up to 400 Bar (CODE/AP)

PERDITE DI CARICO PRESSURE DROPS CURVE

Temperatura olio: 50°C - Viscosità olio: 30 cSt
Oil temperature: 50°C - Oil viscosity: 30 cSt

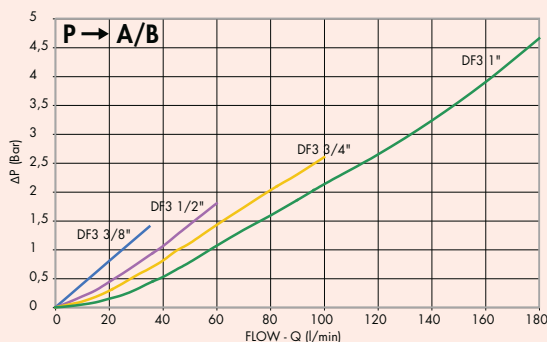

CODICE
CODE

SIGLA
TYPE

PORTATA MAX
MAX FLOW
Lt./min

PRESSIONE MAX
MAX PRESSURE
Bar

V0880	DF 3 VIE 3/8"	35	250
V0890	DF 3 VIE 1/2"	60	250
V0900	DF 3 VIE 3/4"	100	250
V0910	DF 3 VIE 1"	180	250

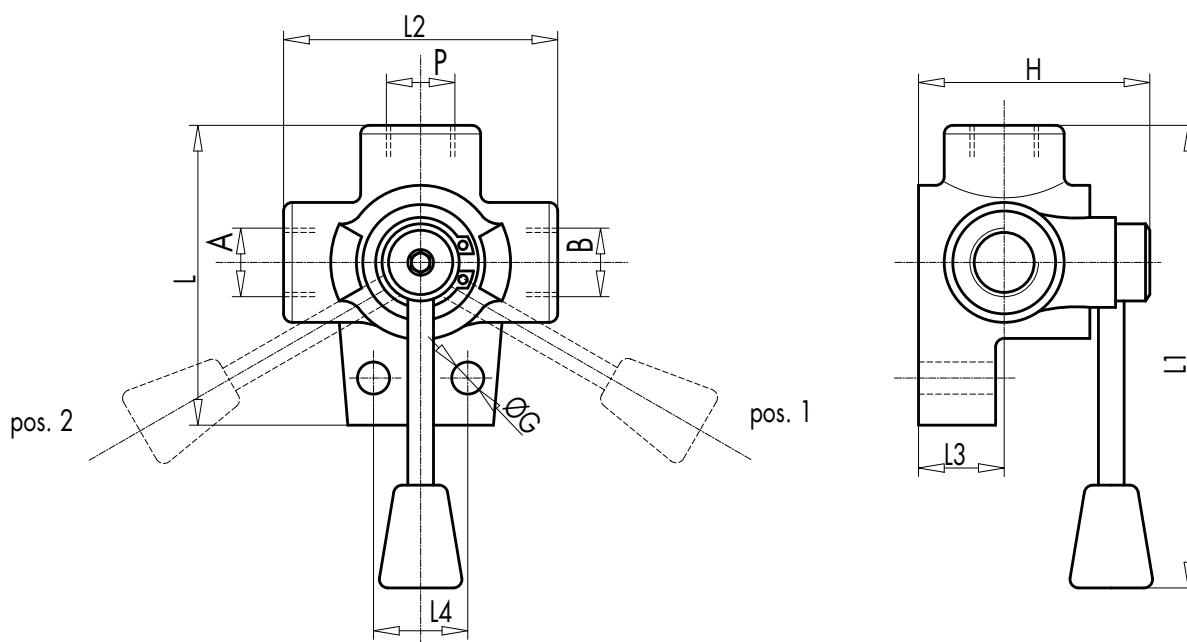

12

CODICE CODE	SIGLA TYPE	A - B P	L	L1	L2	L3	L4	ØG	H	PESO WEIGHT
		GAS	mm	mm	mm	mm	mm	mm	mm	Kg
V0880	DF 3 VIE 3/8"	G 3/8"	76	140	68	25	26	8,5	67	0,914
V0890	DF 3 VIE 1/2"	G 1/2"	87	145	80	28	32	8,5	70	1,392
V0900	DF 3 VIE 3/4"	G 3/4"	103	150	94	30	32	11	78	2,030
V0910	DF 3 VIE 1"	G 1"	105	152	98	30	32	11	82	2,144