

Schema idraulico
Hydraulic diagram

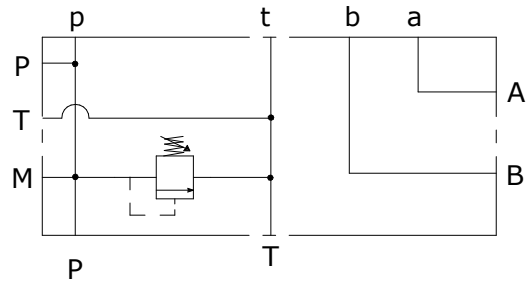

TIPI DI REGOLAZIONE

REGULATION TYPE

	H	VITE CON CHIAVE ESAGONALE(standard) HEXAGONAL HEAD SCREW
	K	POMOLO KNOB
	C	FISSA CON CAPPUCCIO COVER CAP
	I	INVIOLABILE NON ADJUSTABLE

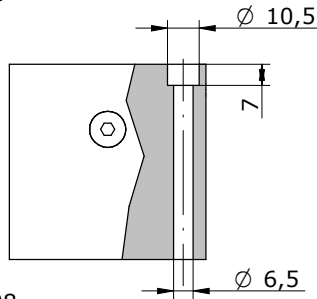

n°2 BSP 3/8G

CAVITY C008
DRV-M20-02*

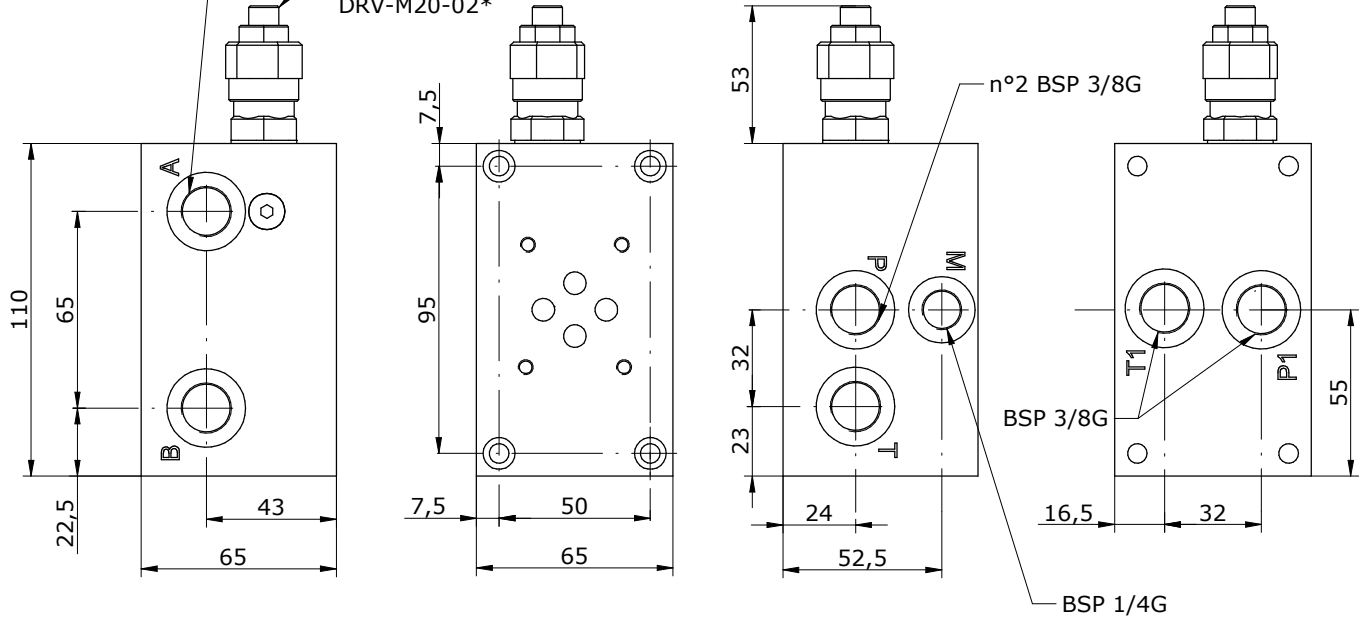

E_ 06 - 10 - 38 - - - -

S = STEEL
A = ALUMINIUM

0 = WITHOUT RELIEF VALVE (PLUGGED CAVITY)
1 = WITH RELIEF VALVE
2 = RELIEF VALVE READY

0 = WITHOUT RELIEF VALVE
H = HEXAGONAL HEAD SCREW
K = KNOB
C = COVER CAP
I = NOT ADJUSTABLE

0 = WITHOUT R.V.
1 = 5-55 bar
2 = 25-110 bar
3 = 50-215 bar
4 = 100-350 bar
5 = 100-420 bar

*see **CARTRIDGE VALVES** datasheets